

SURFACE / BEHIND THE MIRROR

Automatic



DJM0037A
Satin finish body



General Description

- Automatic liquid soap/hand sanitizer dispenser with touch-free operation eliminating cross-contamination, with AISI 304 stainless steel body, for hidden installation behind the mirror.
- Designed to be fitted behind a mirror or panels, this liquid soap/hand sanitizer dispenser helps to ensure that the bathroom remains organized and tidy.
- Delivers an accurate liquid soap/hand sanitizer dosage by simply approaching one's hands, without users contact, avoiding cross-contamination and creating an environment without germs and totally automated.
- 1,000ml refillable plastic container, with easy access to replenish the liquid soap/hand sanitizer.
- Operates on 6 AA alkaline batteries (**not provided**) or **optionally**, with an AC adapter. Order reference DJM0037A-TRAFO to receive the automatic liquid soap/hand sanitizer dispenser able to be connected to the mains with the AC adapter.
- Suitable for liquid soap or hand sanitizing gels.
- It is recommended to use liquid soap or hand sanitizer with the following characteristics:
 - Maximum alcohol content of 80%
 - Density between 0.9 and 1.35 kg / dm³
 - Viscosity between 500 and 2,500 cps.

It does not support soaps that contain methanol, chlorine or solid or abrasive particles.

- Screws and plastic plugs to mount on a brick wall supplied.

Components & materials

- **WALL PLATE:** made of stainless steel AISI 304, 0.8 mm thick. It is mounted on the wall by means of four Ø4 stainless steel screws (provided) with their corresponding Ø 6mm plastic plugs (also provided).
- **INNER PLASTIC TANK:** prevents oxidation and can be easily removed for cleaning and disinfection purposes.
- **VALVE:** anti-drip corrosion resistant that dispenses 1.5 ml of soap per service.
- **POWER:** 6 AA alkaline batteries (not provided) or **optionally**, AC adapter. Order reference DJM0037A-TRAFO to receive the automatic soap dispenser able to be connected to the mains with the electrical transformer.
- **INFRA-RED DETECTION RANGE:** between 8 and 12 cm.

Technical specifications

Dimensions	241 x 105 x 117 mm
Maximum capacity	1 L
Body, cover & base plate	0.8 mm
Inner tank thickness	2.5 mm
Net weight	0.64 Kg
Quantity dispensed per pump	1.5 ml
Detection range	8 – 12 cm

Dimensions

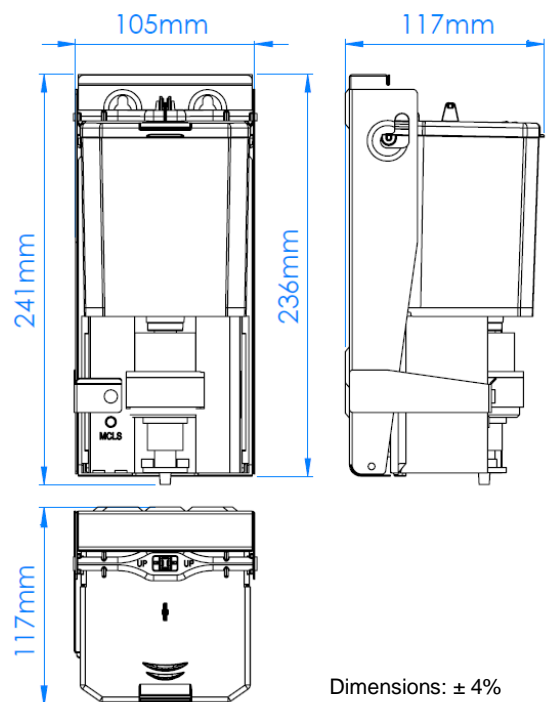

MOUNTING TEMPLATE

Fix the soap dispenser through the holes of the wall and floor plates, using the stainless steel screws supplied and taking into account the distances of the points indicated by an "S" in the next figure:

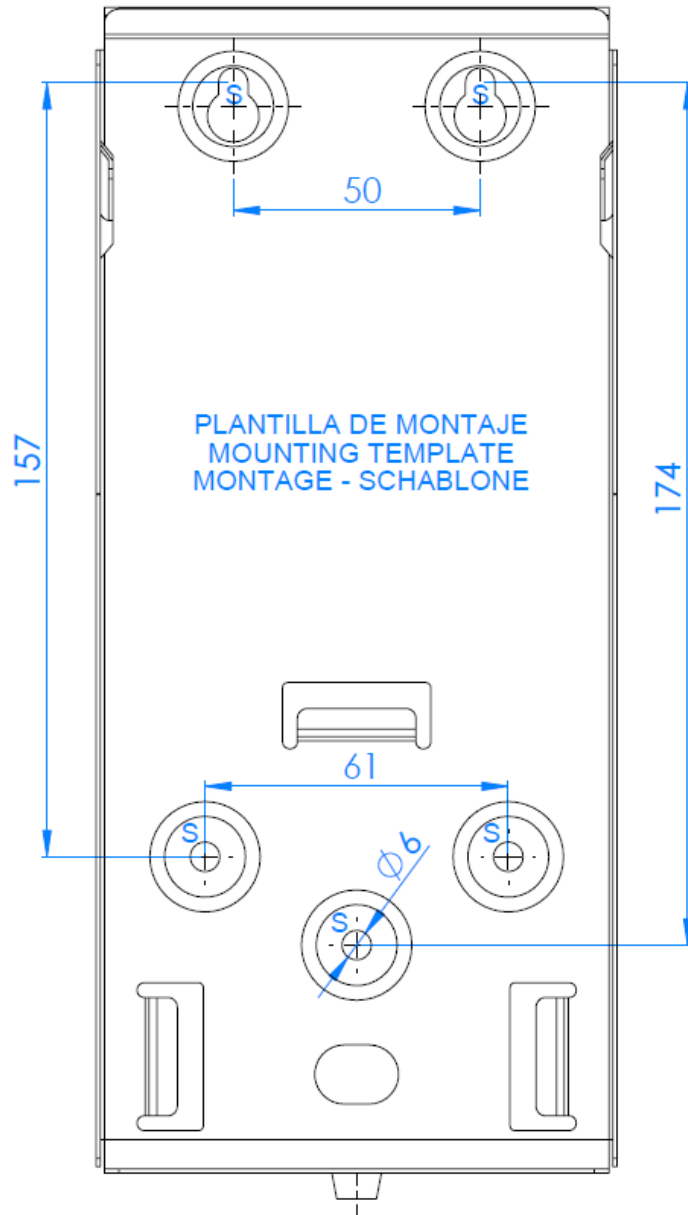

VERY IMPORTANT: do not install this soap dispenser inside the shower, as its electrical components can be seriously damaged by water and the dispenser would stop working. If you choose the configuration with an electric converter, install it away from any source of water.

Mediclinics, S.A., reserves the right to make changes and/or modifications to the products and their specifications without prior notice
Review 09-22 © mediclinics S.A.

