

**SURFACE / BEHIND THE MIRROR**

**Automatic**



**DJSM0039A**  
Satin finish body



## General Description

- Automatic hand sanitizer spray dispenser with touch-free operation eliminating cross-contamination, with AISI 304 stainless steel body, for hidden installation behind the mirror.
- Designed to be fitted behind a mirror or panels, this spray hand sanitizer dispenser helps to ensure that the bathroom remains organized and tidy.
- Delivers an accurate hand sanitizer dosage by simply approaching one's hands, without users contact, avoiding cross-contamination and creating an environment without germs and totally automated.
- 1,000ml refillable plastic container, with easy access to replenish the hand sanitizer.
- Operates on 6 AA alkaline batteries (**not provided**) or **optionally**, with an AC adapter. Order reference DJSM0039A-TRAFO to receive the automatic hand sanitizer spray dispenser able to be connected to the mains with the AC adapter.
- Suitable for hand sanitizer spray.
- It is recommended to use hand sanitizer spray with the following characteristics:
  - Maximum alcohol content of 85%
  - Maximum density of 0.8 kg/dm<sup>3</sup>
  - Use specific spray products.

**It does not support hand sanitizers that contain methanol, chlorine or solid abrasive particles.**

- Screws and plastic plugs to mount on a brick wall supplied.

## Components and materials

- **WALL PLATE:** made of stainless steel AISI 304, 0.8 mm thick. It is mounted on the wall by means of four Ø4 stainless steel screws (provided) with their corresponding Ø 6mm plastic plugs (also provided).
- **INNER PLASTIC TANK:** prevents oxidation and can be easily removed for cleaning and disinfection purposes.
- **VALVE:** anti-drip corrosion resistant that dispenses 0.165 ml of hand sanitizer per service.
- **POWER:** 6 AA alkaline batteries (not provided) or **optionally**, AC adapter. Order reference DJSM0039A-TRAFO to receive the automatic soap dispenser able to be connected to the mains with the electrical transformer.
- **INFRA-RED DETECTION RANGE:** between 8 and 12 cm.

## Technical specifications

<b>Dimensions</b>	241 x 105 x 117 mm
<b>Maximum capacity</b>	1 L
<b>Body, cover &amp; base plate thickness</b>	0.8 mm
<b>Inner tank thickness</b>	2.5 mm
<b>Net weight</b>	0.64 Kg
<b>Quantity dispensed per pump</b>	0.165 ml
<b>Detection range</b>	8 – 12 cm

## Dimensions

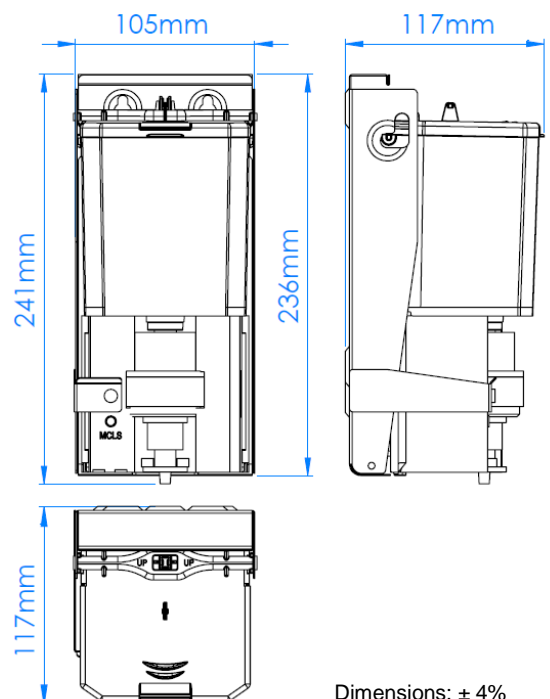

Dimensions: ± 4%

## MOUNTING TEMPLATE

Fix the hand sanitizer dispenser through the holes of the wall and floor plates, using the stainless steel screws supplied and taking into account the distances of the points indicated by an "S" in the next figure:

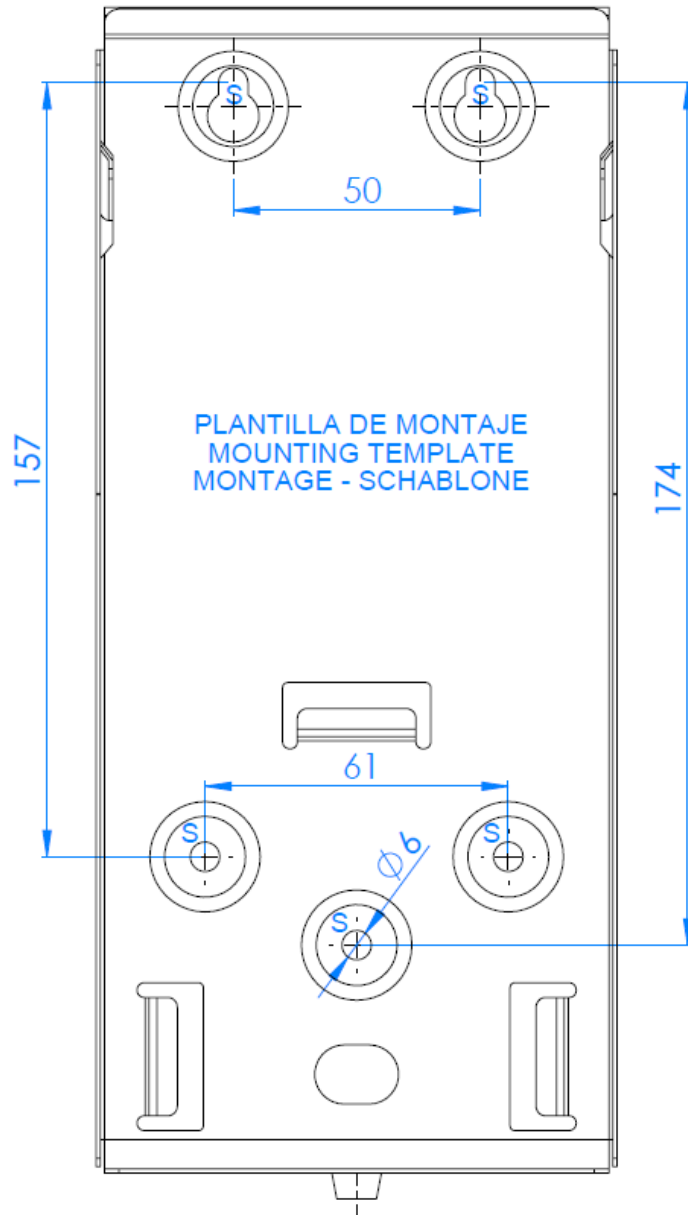

**VERY IMPORTANT:** do not install this hand sanitizer dispenser inside the shower, as its electrical components can be seriously damaged by water and the dispenser would stop working. If you choose the configuration with an electric converter, install it away from any source of water.

Mediclinics, S.A., reserves the right to make changes and/or modifications to the products and their specifications without prior notice  
Review 09-22 © mediclinics S.A.

